

Warning

Read this document to the end. It is very important that you do so or you may have important doubts about what we want to communicate.

Disclaimer

The following information refers to a non-profit altruistic development within the framework of the fight against COVID19.

Keep in mind that the correct way to obtain these devices is to order them from approved manufacturers, therefore, as soon as you have the opportunity to receive these products from a manufacturer, you must use that channel.

Also note that there are patents on this type of device. It is known that manufacturing companies are donating plans and advice, however starting a production for profit, for example, it could be violating patent rights. There has been no study of intellectual property that could be affected by the use of the product in each of the territories. Get informed.

Files must be analyzed and validated before use. It is also necessary for a health authority to be responsible for the validation of the product resulting from the use of these contents. Do not use in a medical treatment a product not validated by a health professional and the proper health authorities.

In any case, our intention is to inspire and provide previous work to all those who can take these files and can take responsibility for putting in place a safe solution that saves lives. This necessarily involves verifying that the technical solution that we propose is viable, with the corresponding organizations in your country, and that the solution that you propose based on these elements that we make available to you, does not pose a health hazard.

We present the results of the tests carried out, and we make a series of recommendations that you must verify for yourself, and verify that under the conditions that you are going to implement this solution, the system works as you need it to work.

If you do not have the possibility of assuring 100% that the result of the device that you are going to manufacture from these plans is safe and effective, you should know that the responsibility for the damages that it may cause is solely yours, and that is why we ask that you put this solution in the hands of your local administration or government so that you receive expert assistance, and its implementation is 100% safe and verified by experts.

While the pandemic lasts and there is a need in your country that cannot be satisfied by the commercial offer of these devices, you have our permission to use, modify and distribute these files, including this document, always under your responsibility. If you modify the design, this document is no longer valid, and you do not have the right to use it, unless you modify it, therefore, you are responsible for everything that appears in that new version.

If you, despite having these files, cannot manufacture the helmet, contact us on the web <https://breathingbubble.com> to see if we can help you, or write to us at hi@breathingbubble.com indicating your contact details.

Understanding that in some cases it is this or nothing, I wish with all my heart that you can find a solution inspired by our work, and can save other people's lives.

A greeting and good luck,



J. de Donostia





WARNING – IMPORTANT INFORMATION

- **Manufacture this device so that it is a physical barrier to COVID19. Some materials are porous, and although they appear solid and waterproof, they are not. You must make sure that the material you use is watertight, or that you can treat it to make it watertight, otherwise the virus will infect the environment.**
- **Please note that the patient must wear earplugs to withstand the pressure inside the helmet. Try to use a plastic bubble as transparent as possible so that the patient can at least see, since they will hear very little.**
- **In this design, moorings are placed so that the helmet can be fixedly attached to the body, by means of straps that would be located under the armpits.**
- **Never use the helmet without a filter, or you'll spread the virus all over the room.**











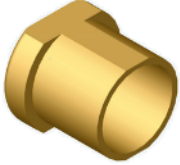



Technical Files Index (Designed in Solid Works 2000)				
Ring type	File	Piece	Description	Download link
Modular ring	4674Z.pdf	Top plastic bubble 	Drawing of the part	https://thebreathinbubble.weebly.com/uploads/1/3/1/6/131681139/4674z.pdf
Modular ring	4674S.pdf	Top plastic bubble 	Rendering of the part	https://thebreathinbubble.weebly.com/uploads/1/3/1/6/131681139/4674s.pdf
Modular ring	4677F.step	Tightening clamp 	Solid editable by the receiver	https://thebreathinbubble.weebly.com/uploads/1/3/1/6/131681139/4677f.step

Modular ring	4677FS.pdf	Tightening clamp 	Rendering of the part	https://thebreathinbubble.weebly.com/uploads/1/3/1/6/131681139/4677fs.pdf
Modular ring	4677FZ.pdf	Tightening clamp 	Drawing of the part	https://thebreathinbubble.weebly.com/uploads/1/3/1/6/131681139/4677fz.pdf
Modular ring	4681.step	Ring 	Solid editable by the receiver	https://thebreathinbubble.weebly.com/uploads/1/3/1/6/131681139/4681.step
Modular ring	4681S.pdf	Ring 	Rendering of the part	https://thebreathinbubble.weebly.com/uploads/1/3/1/6/131681139/4681s.pdf
Modular ring	4681Z.pdf	Ring 	Drawing of the part	https://thebreathinbubble.weebly.com/uploads/1/3/1/6/131681139/4681z.pdf
Modular ring	4682.step	Strap tie 	Solid editable by the receiver	https://thebreathinbubble.weebly.com/uploads/1/3/1/6/131681139/4682.step
Modular ring	4682S.pdf	Strap tie 	Rendering of the part	https://thebreathinbubble.weebly.com/uploads/1/3/1/6/131681139/4682s.pdf

Modular ring	4682Z.pdf	Strap tie 	Drawing of the part	https://thebreathinbubble.weebly.com/uploads/1/3/1/6/131681139/4682z.pdf
Modular ring	4683.step	Support socket connector 	Solid editable by the receiver	https://thebreathinbubble.weebly.com/uploads/1/3/1/6/131681139/4683.step
Modular ring	4683S.pdf	Support socket connector 	Rendering of the part	https://thebreathinbubble.weebly.com/uploads/1/3/1/6/131681139/4683s.pdf
Modular ring	4683Z.pdf	Support socket connector 	Drawing of the part	https://thebreathinbubble.weebly.com/uploads/1/3/1/6/131681139/4683z.pdf
Modular ring	4684.step	Support socket for oxygen 	Solid editable by the receiver	https://thebreathinbubble.weebly.com/uploads/1/3/1/6/131681139/4684.step
Modular ring	4684S.pdf	Support socket for oxygen 	Rendering of the part	https://thebreathinbubble.weebly.com/uploads/1/3/1/6/131681139/4684s.pdf
Modular ring	4684Z.pdf	Support socket for oxygen 	Drawing of the part	https://thebreathinbubble.weebly.com/uploads/1/3/1/6/131681139/4684z.pdf

Modular ring	4685.step	Air intake connector 	Solid editable by the receiver	https://thebreathinbubble.weebly.com/uploads/1/3/1/6/131681139/4685.step
Modular ring	4685S.pdf	Air intake connector 	Rendering of the part	https://thebreathinbubble.weebly.com/uploads/1/3/1/6/131681139/4685s.pdf
Modular ring	4685Z.pdf	Air intake connector 	Drawing of the part	https://thebreathinbubble.weebly.com/uploads/1/3/1/6/131681139/4685z.pdf
Modular ring	4688.step	Silicone disc 	Solid editable by the receiver	https://thebreathinbubble.weebly.com/uploads/1/3/1/6/131681139/4688.step
Modular ring	4688S.pdf	Silicone disc 	Rendering of the part	https://thebreathinbubble.weebly.com/uploads/1/3/1/6/131681139/4688s.pdf
Modular ring	4688Z.pdf	Silicone disc 	Drawing of the part	https://thebreathinbubble.weebly.com/uploads/1/3/1/6/131681139/4688z.pdf
Modular ring	4694.step	Sockets connector plug 	Solid editable by the receiver	https://thebreathinbubble.weebly.com/uploads/1/3/1/6/131681139/4694.step

Modular ring	4694S.pdf	Sockets connector plug 	Rendering of the part	https://thebreathinbubble.weebly.com/uploads/1/3/1/6/131681139/4694s.pdf
Modular ring	4694Z.pdf	Sockets connector plug 	Drawing of the part	https://thebreathinbubble.weebly.com/uploads/1/3/1/6/131681139/4694z.pdf
Compact ring	4674Z.pdf	Top plastic bubble 	Drawing of the part	https://thebreathinbubble.weebly.com/uploads/1/3/1/6/131681139/4674z.pdf
Compact ring	4674S.pdf	Top plastic bubble 	Rendering of the part	https://thebreathinbubble.weebly.com/uploads/1/3/1/6/131681139/4674s.pdf
Compact ring	4675F.step	Complete set 	Solid editable by the receiver	https://thebreathinbubble.weebly.com/uploads/1/3/1/6/131681139/4675f.step

Compact ring	4675FS.pdf	Complete set 	Rendering of the part	https://thebreathinbubble.weebly.com/uploads/1/3/1/6/131681139/4675fs.pdf
Compact ring	4675Z.pdf	Complete set 	Drawing of the part	https://thebreathinbubble.weebly.com/uploads/1/3/1/6/131681139/4675z.pdf
Compact ring	4676F.step	Ring 	Solid editable by the receiver	https://thebreathinbubble.weebly.com/uploads/1/3/1/6/131681139/4676f.step
Compact ring	4676FS.pdf	Ring 	Rendering of the part	https://thebreathinbubble.weebly.com/uploads/1/3/1/6/131681139/4676fs.pdf
Compact ring	4676FZ.pdf	Ring 	Drawing of the part	https://thebreathinbubble.weebly.com/uploads/1/3/1/6/131681139/4676fz.pdf
Compact ring	4677F.step	Tightening clamp 	Solid editable by the receiver	https://thebreathinbubble.weebly.com/uploads/1/3/1/6/131681139/4677f.step
Compact ring	4677FS.pdf	Tightening clamp 	Rendering of the part	https://thebreathinbubble.weebly.com/uploads/1/3/1/6/131681139/4677fs.pdf
Compact ring	4677FZ.pdf	Tightening clamp 	Drawing of the part	https://thebreathinbubble.weebly.com/uploads/1/3/1/6/131681139/4677fz.pdf

Compact ring	4688.step	Silicone disc 	Solid editable by the receiver	https://thebreathinbubble.weebly.com/uploads/1/3/1/6/131681139/4688.step
Compact ring	4688S.pdf	Silicone disc 	Rendering of the part	https://thebreathinbubble.weebly.com/uploads/1/3/1/6/131681139/4688s.pdf
Compact ring	4688Z.pdf	Silicone disc 	Drawing of the part	https://thebreathinbubble.weebly.com/uploads/1/3/1/6/131681139/4688z.pdf
Compact ring	4694.step	Sockets connector plug 	Solid editable by the receiver	https://thebreathinbubble.weebly.com/uploads/1/3/1/6/131681139/4694.step
Compact ring	4694S.pdf	Sockets connector plug 	Rendering of the part	https://thebreathinbubble.weebly.com/uploads/1/3/1/6/131681139/4694s.pdf
Compact ring	4694Z.pdf	Sockets connector plug 	Drawing of the part	https://thebreathinbubble.weebly.com/uploads/1/3/1/6/131681139/4694z.pdf

Assembly instructions for the helmet with modular ring

STEP 1



②



③



④



The modular ring has the characteristic of being able to be printed on a 3D printer with a surface of 250 x 250.

This is possible because their connectors are printed separately, and therefore must be attached in a second step to the ring using an adhesive.

For the pieces to be glued, a margin of between 250 and 300 microns has been considered between the pieces.

Use a glue suitable for the type of plastics you are going to use. 3M company has solutions.

① Modular ring.

② Auxiliary socket connector.

③ Connector for the sanitary air intake.

④ Oxygen intake connector.

⑤



⑥



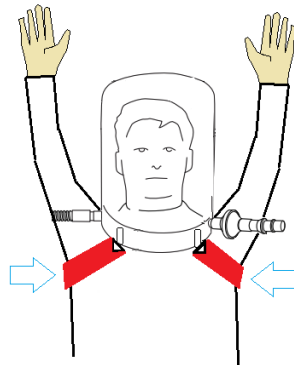

⑤ Plug for the shots.

⑥ Tying (for adjustment straps below the armpits, see image below).

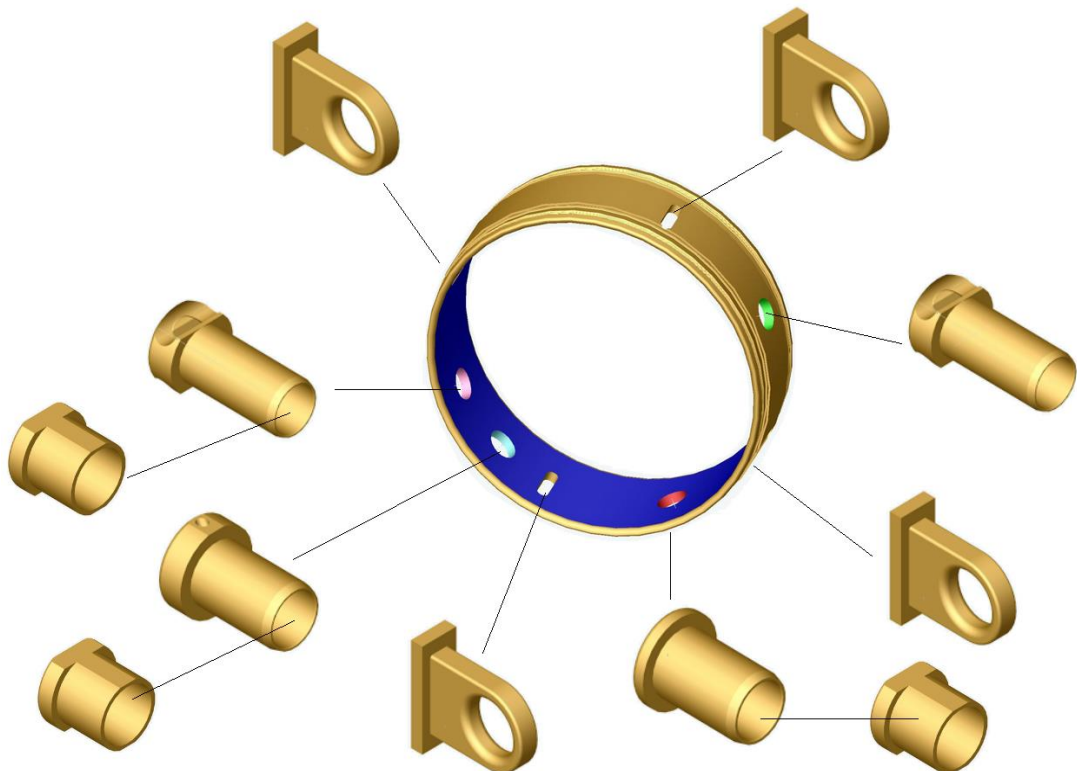

STEP 2



	<p>Glue the pieces in the areas of contact with the ring. Use a glue suitable for the type of plastics you have used to manufacture these parts (3M company has some solutions that you can use).</p> <p>Insert the pieces from inside the ring, and press against the wall until they stop.</p>
---	--

STEP 3

	<p>Take the ring with all the pieces assembled. Position it correctly according to these instructions, so you know which is the bottom and which is the top:</p> <p>Standing in front of the ring placed on a horizontal surface, you should have two sockets exactly at 0° and 180°, with two sockets on the left side, just in front of you one socket, and on the right one socket. Located in front of the piece you should see what you see in the image on the left.</p>
--	--

STEP 4

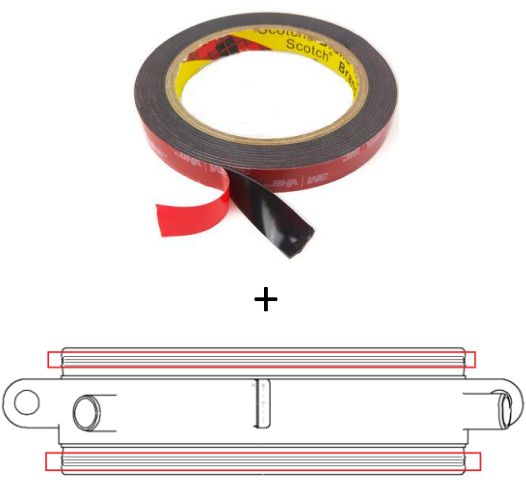
	<p>Surround the grooved edge with double-sided tape of a certain thickness to act as an adhesive and an O-ring. 3M is the brand we have used and it works well.</p> <p>If you do not have this double-sided tape, you can use a silicone tape that acts as an O-ring. Make sure that the material you use is soft and thick enough so that a perfect seal is achieved when the upper transparent plastic is pressed against the ring with the cable ties.</p> <p>In the case of the silicone that is located in the lower part of the helmet, the same silicone will act as an O-ring.</p>
---	--

STEP 5

①

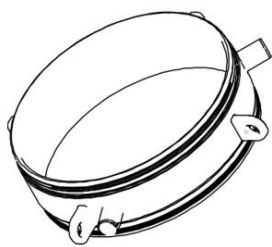

+

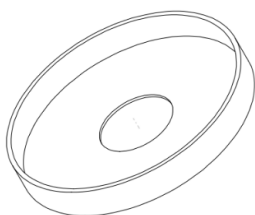

+

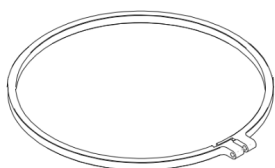

②



③



④



① Take the ring, the silicone and a clamping clamp.

② ③ Place the silicone in the ring. Silicone must be flexible to fit the patient's neck.

The diameter of the helmet entry hole should be less than the diameter of the patient's neck. In this way, the silicone will stick along the patient's neck several centimeters, forming a watertight seal. You can make this tightness firmer, with adhesive tape surrounding the silicone that compresses the neck, taking care not to suffocate the patient.

In turn, the silicone must have a sufficient resistance to pressure and not swell too much.

We have used Dragon Skin™ 10 brand silicone Smooth-on (www.smooth-on.com), verify that this silicone or another of the same characteristics are valid for the result you expect.

④ Once the silicone is placed in the ring, add the clamp and tighten it with a screw plus a butterfly bolt&nut, without forcing too much, since it can tear the silicone if you apply a lot of pressure.

STEP 6

①

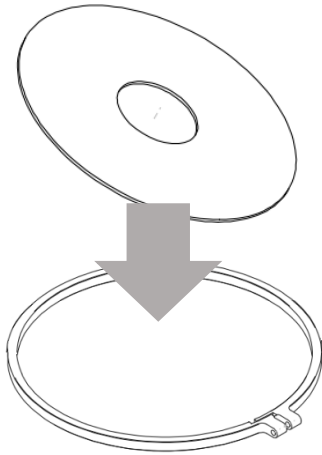

②

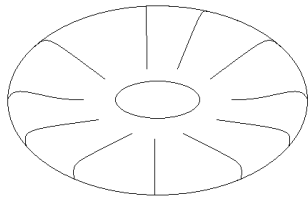

③

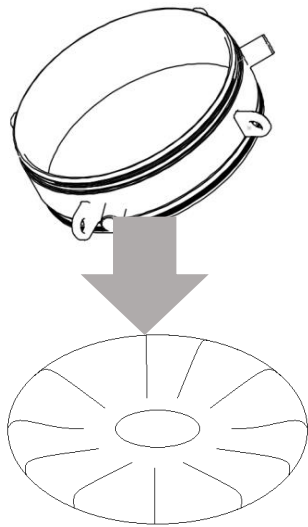

④



Mounting with silicone flat disk:

If you do not have a mold to make the silicone part, you can make a flat piece of 275 mm / 280 mm outer diameter, and an inner hole that will depend on the diameter of the patient's neck (see the next step for more information on the diameter of the entrance hole to the helmet).

① Place the clamp on a flat surface.

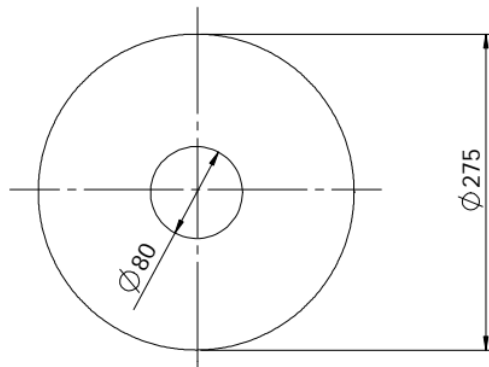

② Cover the clamp with the flat silicone disc, centered, causing the excess silicone to overflow and fall around the perimeter of the clamp.

③ Place the ring on top of all of the above and fit the piece into the clamp.

④ Once the silicone is placed in the ring, add the clamp and tighten it with a screw plus a butterfly bolt&nut, without forcing too much, since it can tear the silicone if you apply a lot of pressure.

The silicone will tend to deform and fill the gap between clamp and ring.

STEP 7

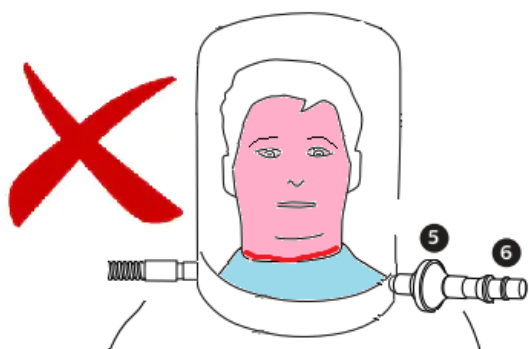

Please note that the neck entry hole must have a diameter adapted to the patient's neck. We indicate a diameter of 80 mm as a guide for a neck of a non-obese person. In the case of people with a thicker neck, they should increase that diameter so as not to oppress the patient's neck and cause injury, suffocation or a cut in the blood supply to the head.

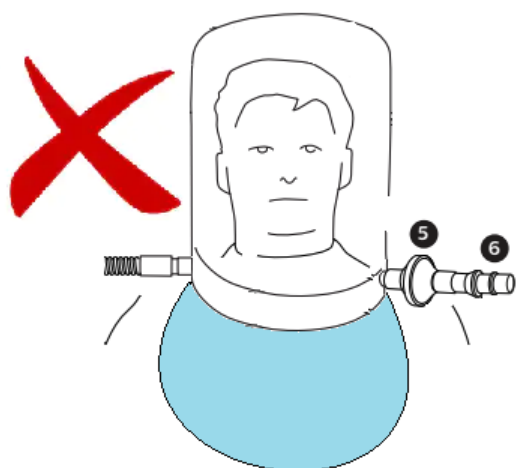

Also note that if you use too flexible a silicone, when you put pressure on the helmet, that silicone will give way and inflate like a balloon. Use a silicone that is not too flexible to keep a balance with the comfort of the patient.

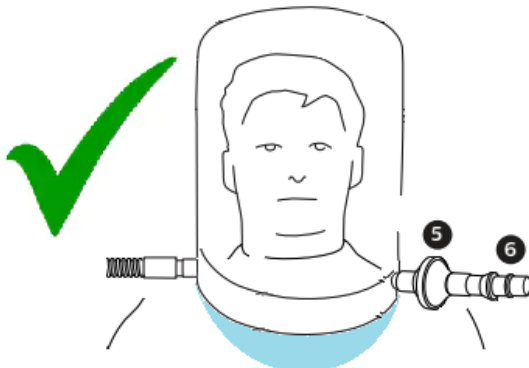

STEP 8

①

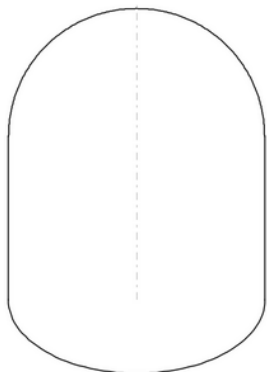

① Add the clear plastic bubble. We recommend that the material be 0.3mm clear PVC, although 0.075mm polyethylene may work. However, check that the pressure at which the helmet is going to work does not require a material thicker than 0.075 mm.

+

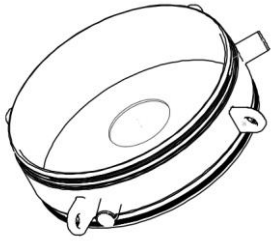

②

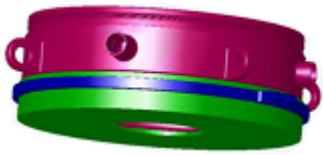

③



④



② On the set resulting from the previous step,

③ snap the clear plastic bubble onto the ring,

④ Attach the clamp from the top, and tighten the clamp so that the bubble wrap is pressed against the adhesive tape, which acts as an O-ring, and the ring.

STEP 9

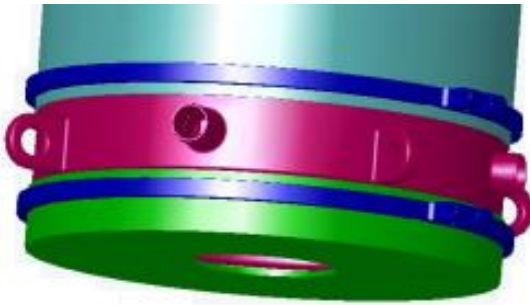

Place and tighten the clamps with screws, with a nut or butterfly bolt&nut, so that the clamps cover the entire grooved perimeter, and press the transparent plastic bubble and the silicone against the grooved area of the ring, so that there are no gaps for air to escape.

Make sure that part of the clear plastic and part of the silicone are beyond the clamping clamp, extending further along the surface of the outer face of the ring, as if they were to meet halfway.



If you do not have the clamps that we have designed, you can replace them with normal clamps. In this case, you should pay special attention to the area of the clamp head, since this area will not conform to the surface of the ring. At this point, add silicone or another similar material that acts as a filler, and that due to its flexibility fits perfectly in the hole.

For example, use flat head clamps type HellermannTyton to improve the fit of the clamp head.

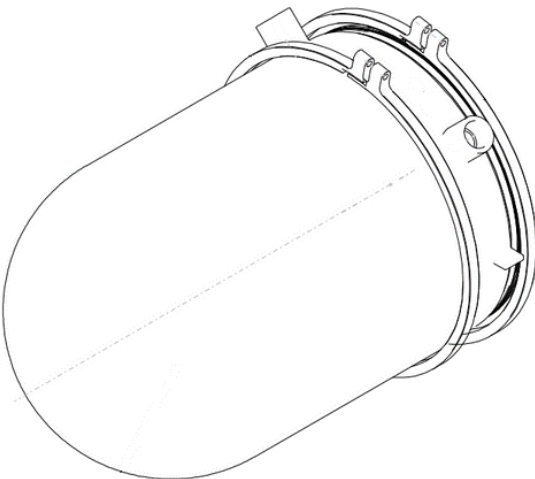

Do not overtighten the clamp or it will tear the silicone. When the silicone is firm and cannot be easily removed by pulling it, it is time to stop tightening the clamp.

STEP 10

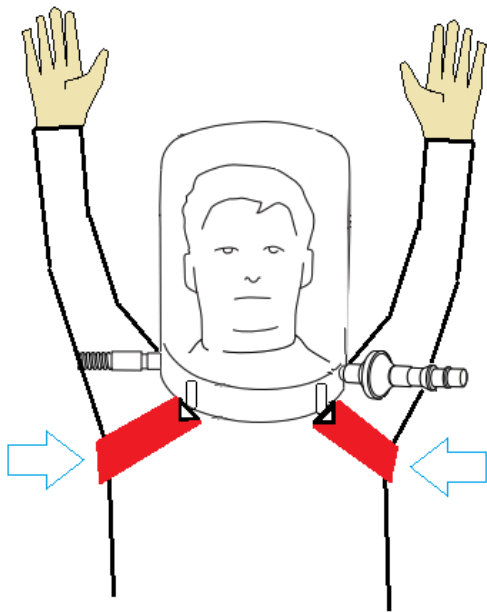

Attach straps to give stability to the helmet. Tie one end of the strap to the front tie, pull it under the armpit, and hook it into the tie at the back.

STEP 11

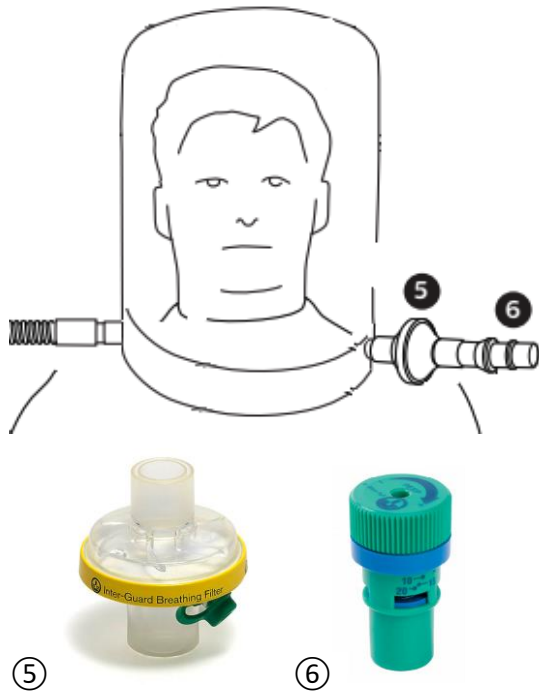

Always add the air filter and the peep valve. In extreme cases, you can regulate the interior pressure of the helmet using the filter resistance.



Never use the device without the air filter or it will quickly spread the virus around the room.

STEP 10A



Use the plugs to close the non used connectors.

Assembly instructions for the helmet with compact ring

STEP 1A



Take a ring.
Position it correctly according to these instructions, so you know which is the bottom and which is the top:
Standing in front of the ring placed on a horizontal surface, you should have two sockets exactly at 0° and 180°, with two sockets on the left side, just in front of you one socket, and on the right one socket. Located in front of the piece you should see what you see in the image on the left.

STEP 2A

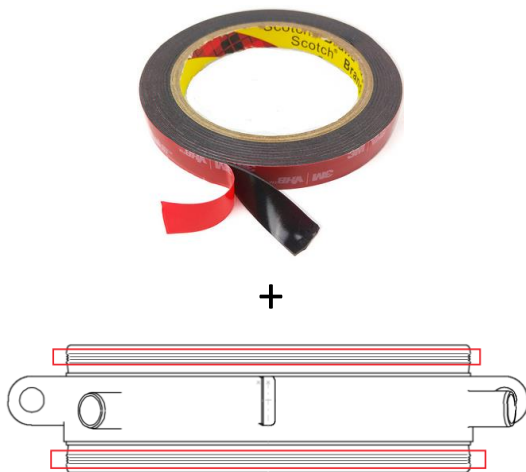

Surround the grooved edge with double-sided tape of a certain thickness to act as an adhesive and an O-ring. 3M is the brand we have used and it works well.
If you do not have this double-sided tape, you can use a silicone tape that acts as an o-ring. Make sure that the material you are using is soft and thick enough so that a perfect seal is achieved when the upper transparent plastic is pressed against the ring with the cable ties.
In the case of the silicone that is located in the lower part of the helmet, the same silicone will act as an O-ring.

STEP 3A

①

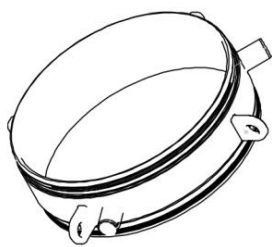

+

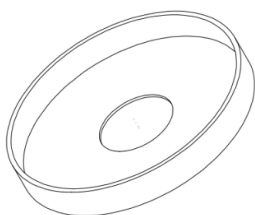

+

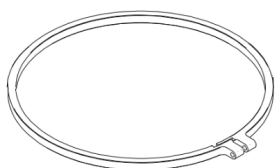

②



③



④



①②③ Place the silicone in the ring. Silicone must be flexible to fit the neck. The diameter of the helmet entry hole should be less than the diameter of the patient's neck. In this way, the silicone will stick along the patient's neck several centimeters, forming a watertight seal. In turn, the silicone must have a sufficient resistance to pressure and not inflate too much.

We have used Dragon Skin™ 10 brand silicone Smooth-on (www.smooth-on.com), verify that this silicone or another of the same characteristics are valid for the result you expect.

④ Once the silicone is placed in the ring, add the clamp and tighten it with a screw plus a butterfly bolt&nut, without forcing too much, since it can tear the silicone if you apply a lot of pressure.

STEP 4A

①

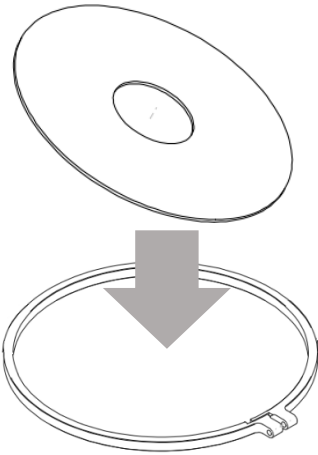

②

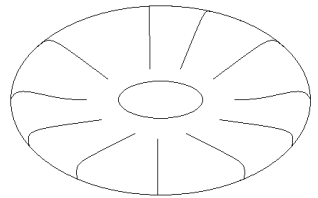

③

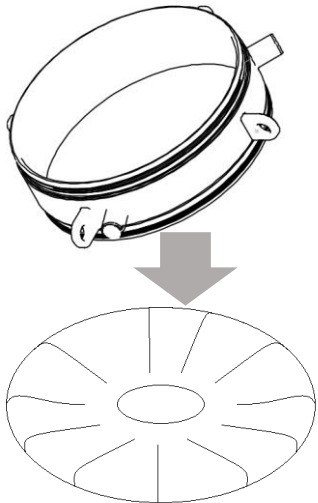

④



Mounting with silicone flat disk:

If you do not have a mold to make the silicone part, you can make a flat piece of 275 mm / 280 mm outer diameter, and an inner hole that will depend on the diameter of the patient's neck (see the next step for more information on the diameter of the entrance hole to the helmet).

① Place the clamp on a flat surface.

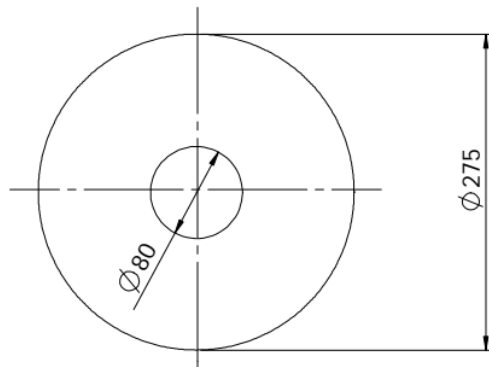

② Cover the clamp with the flat silicone disc, centered, causing the excess silicone to overflow and fall around the perimeter of the clamp.

③ Place the ring on top of all of the above and fit the piece into the clamp.

④ Once the silicone is placed in the ring, add the clamp and tighten it with a screw plus a butterfly bolt&nut, without forcing too much, since it can tear the silicone if you apply a lot of pressure. The silicone will tend to deform and fill the gap between clamp and ring.

STEP 5A

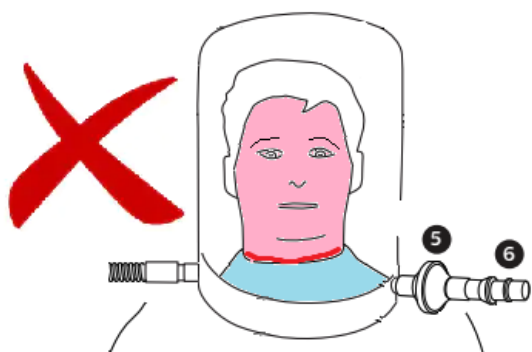

Please note that the neck entry hole must have a diameter adapted to the patient's neck. We indicate a diameter of 80 mm as a guide for a neck of a non-obese person. In the case of people with a thicker neck, they should increase that diameter so as not to oppress the patient's neck and cause injury, suffocation or a cut in the blood supply to the head.

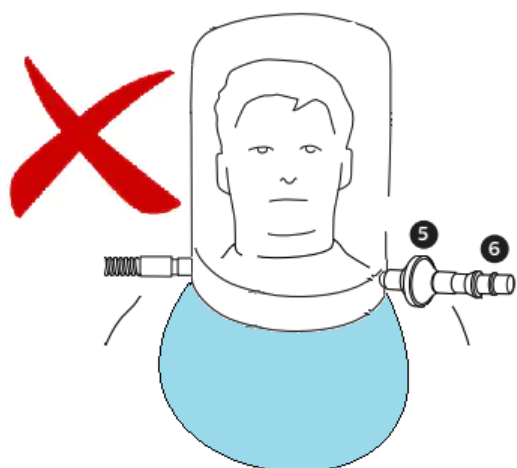

Also note that if you use too flexible a silicone, when you put pressure on the helmet, that silicone will give way and inflate like a balloon. Use a silicone that is not too flexible to keep a balance with the patient's comfort.

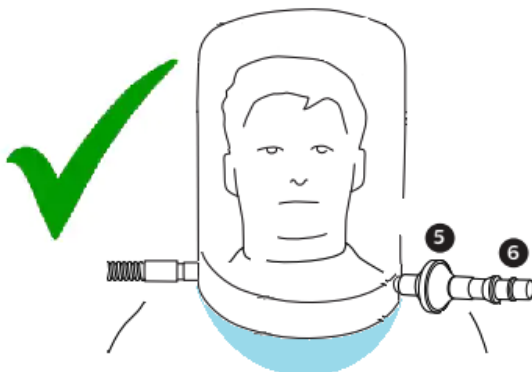

STEP 6A

①

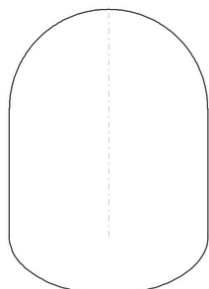

+

① Add the clear plastic bubble. We recommend that the material be 0.3mm clear PVC, although 0.075mm polyethylene may work. However, check that the pressure at which the helmet is going to work does not require a material thicker than 0.075 mm.

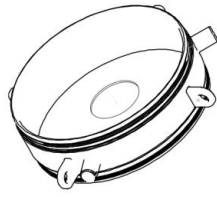

②



③



④



② On the set resulting from the previous step,

③ snap the clear plastic bubble onto the ring,

④ Attach the clamp from the top, and tighten the clamp so that the bubble wrap is pressed against the adhesive tape, which acts as an O-ring, and the ring.

STEP 7A

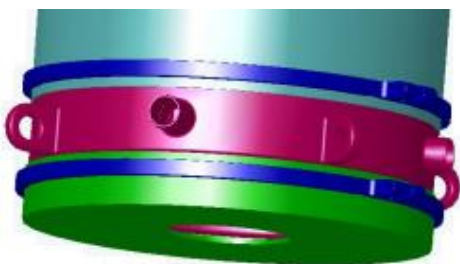

Position and tighten the clamps with a screw plus nut or butterfly bolt&nut, so that they cover the entire grooved perimeter, and press the transparent plastic bubble and the silicone against the grooved area of the ring, so that there are no gaps through which air can escape.

Make sure that part of the clear plastic and part of the silicone are beyond the clamping clamp, extending further along the surface



of the outer ring of the ring, as if they were to meet halfway.

If you do not have the clamps that we have designed, you can replace them with normal clamps. In this case, you must pay special attention to the area of the clamp head, since this area will not fit the surface of the ring. At this point, add silicone or another similar material that acts as a filler, and that due to its flexibility fits perfectly in the hole. For example, use flat head clamps type HellermannTyton to improve the fit of the clamp head.

Do not overtighten the clamp or it will tear the silicone. When the silicone is firm and cannot be easily removed by pulling it, it is time to stop tightening the clamp.

STEP 8^a

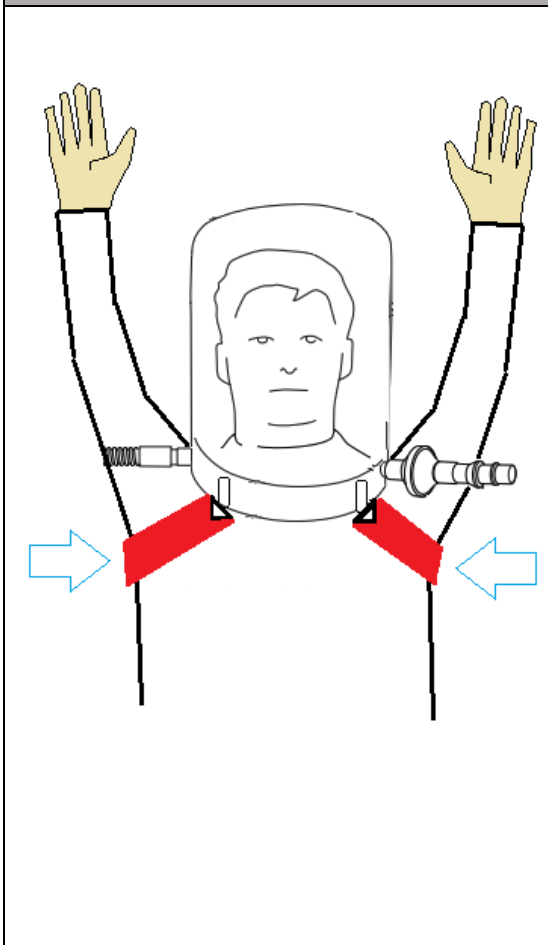

Attach straps to give stability to the helmet.

Tie one end of the strap to the front tie, pull it under the armpit, and hook it into the tie at the back.

STEP 9A

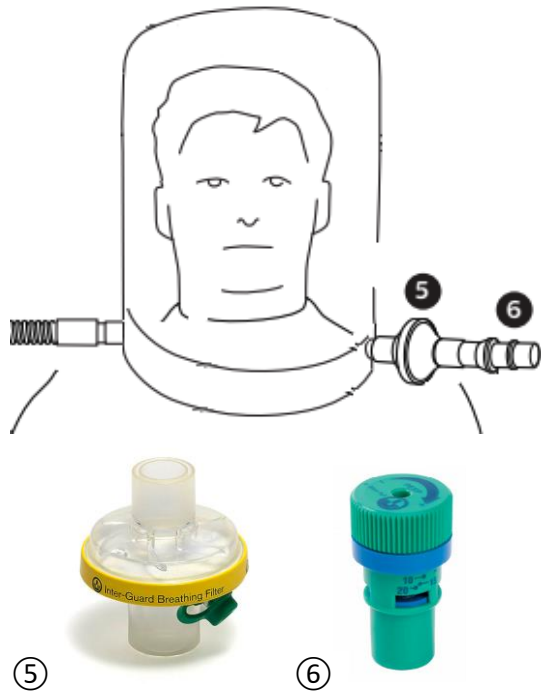

Always add the air filter and the peep valve. In extreme cases, you can regulate the interior pressure of the helmet using the filter resistance.



Never use the device without the air filter or it will quickly spread the virus around the room.

STEP 10A



Use the plugs to close the non used connectors.

Proposal

Our solution is inspired by a diving helmet and its different air intakes and outlets that keep the diver ventilated.

There are solutions on the market similar to the one presented in this document, and which are used in hospitals on a regular basis.



Below is the outline of a typical implementation, which can be simplified in case of extreme need to very few elements, and remain functional:

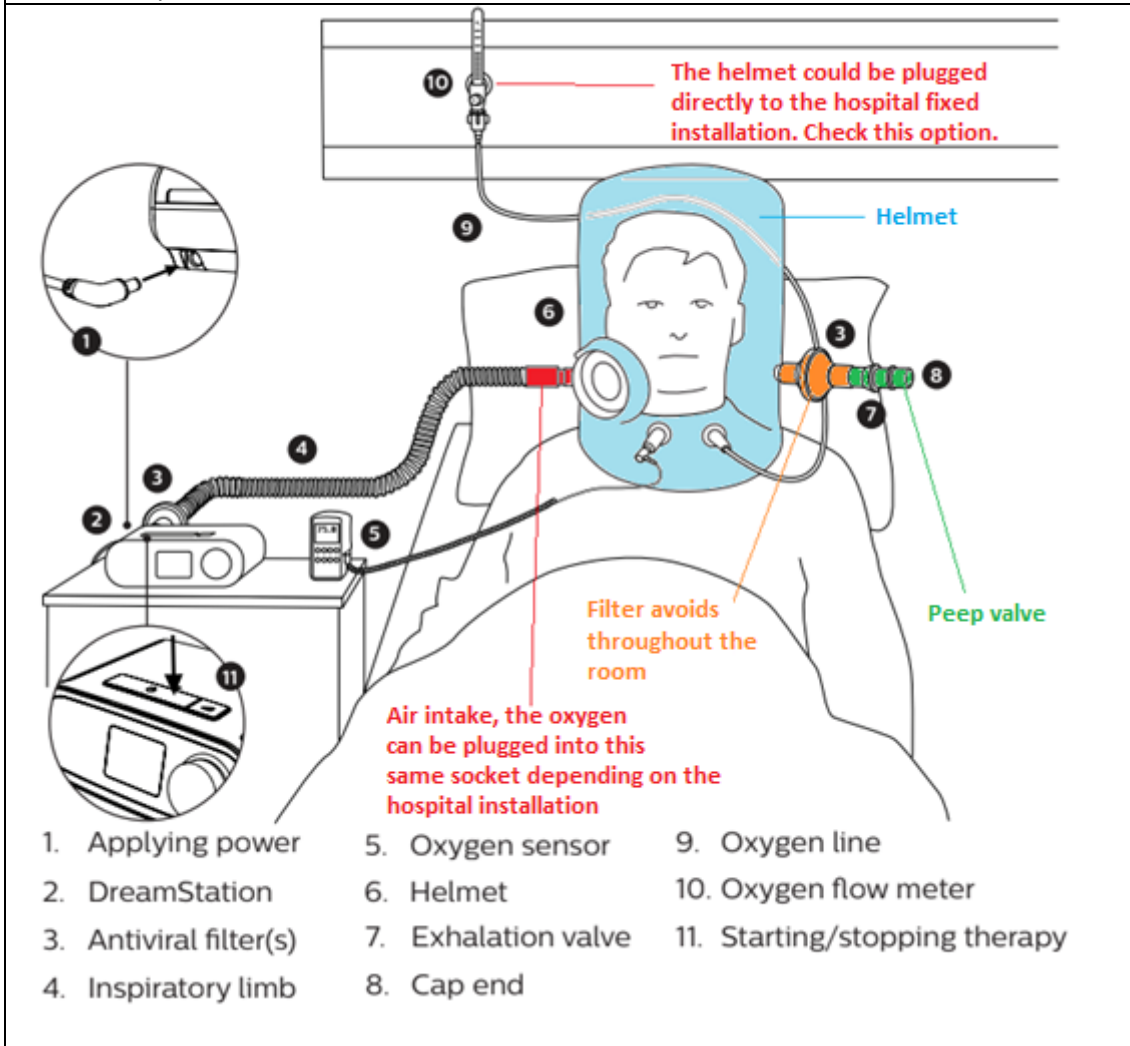

WARNING – VERY IMPORTANT

- This device creates a pressurized space, and therefore has a pressurized air outlet. You should always put a filter in the air outlet, or the virus will spread throughout the room.
- If you put a suitable filter and guarantee the tightness of the entire device, the propagation stops.
- In the intubation and de-intubation operations, you must take into account that there is a high risk of contagion, due to the existence of aerosols. Use a protective screen or protect yourself with PPE.
- The materials in which the parts are manufactured cannot be porous, they must be watertight, otherwise the virus will infect the environment.

- Take into account that this device must have a constant flux of air and pressure, or the patient could suffer asphyxia, and if the patient is unconscious, can cause death. So assure that there is always supply of air/oxygen and pressure.

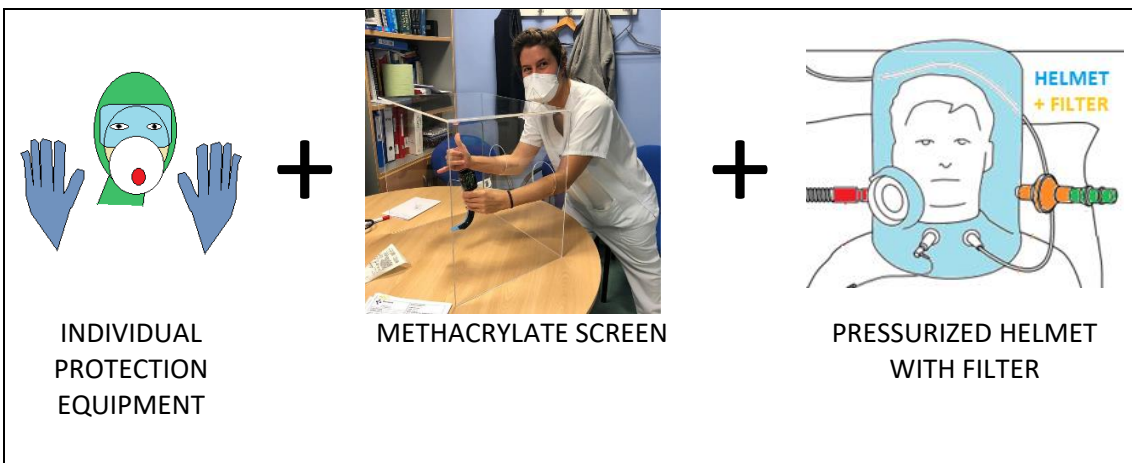

- Advantages**
1. Treatment with O2 intake to avoid collapse and ICU admission for patients who have difficulty breathing, but who can still do it themselves without the need for an invasive system.
 2. Physical barrier that prevents the spread of the patient's COVID19-infected breath to the environment, which prevents infection by healthcare personnel.
 3. Prepared to be connected directly to the sanitary air and oxygen intakes of the fixed hospital installation, or other available ventilating devices.

Our testing

A low quality prototype has been tested in the laboratory at an air inlet flow rate 4 times higher than necessary, and at a pressure 50% higher than necessary.

You can see the video at the following link:

<https://youtu.be/kuKx7GKkE-A>



Photos and videos of the high quality Polyamide 12 ring:

<https://breathingbubble.com/news/>

<https://breathingbubble.com>

hi@breathingbubble.com